

**AWWA C504  
DOUBLE ECCENTRIC  
BUTTERFLY VALVE**

**Model 3975-F  
Class 150B and Class 250B**

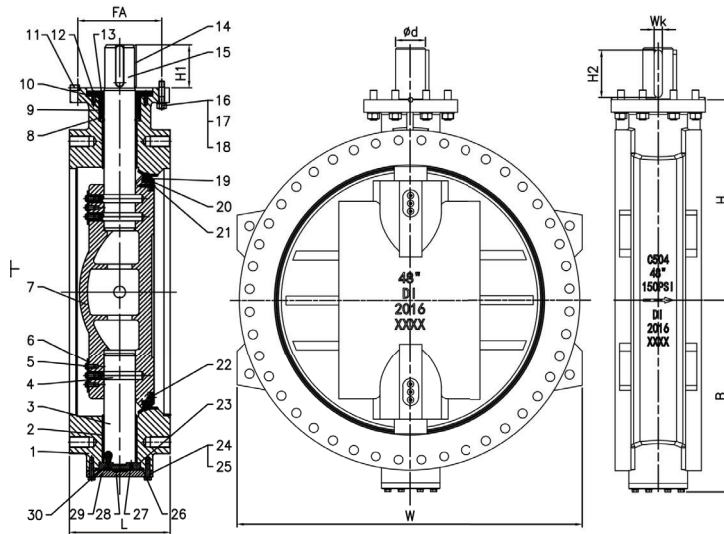

**LIST OF MATERIALS**

Item	Part	Material
1	Body	Ductile Iron
2	Bushing	Bronze
3	Lower Shaft	Stainless Steel 630
4	Pin	Stainless Steel 304
5	Bolts	Stainless Steel 304
6	Plate	Stainless Steel 304
7	Disc	Ductile Iron
8	Y-Ring	NBR
9	O-Ring	NBR
10	O-Ring	NBR
11	Pin	Stainless Steel 304
12	Bolts	Stainless Steel 304
13	Gland	Stainless Steel 304
14	Key	Carbon Steel
15	Upper Shaft	Stainless Steel 630
16	Stud	Stainless Steel 304
17	Hexagon Nut	Stainless Steel 304
18	Washer	Stainless Steel 304
19	T-Sealing Ring	EPDM
20	Holder Plate	Stainless Steel 304
21	Bolts	Stainless Steel 304
22	Bolts	Stainless Steel 304
23	Shaft Retainer	Stainless Steel 304
24	Bolts	Stainless Steel 304
25	Washer	Stainless Steel 304
26	O-Ring	NBR
27	Adjusting Screw	Stainless Steel 304
28	Bottom Cap	Ductile Iron
29	Adjusting Spacer	Bronze
30	Bolts	Stainless Steel 304

**Description:**

1. Valves comply with AWWA C504.
2. Stainless steel 304 seat.
3. EPDM/NBR ring clamped on disc.
4. Actuator-ready with top-flange in accordance with ISO 5211-1.
5. Operated by gearbox with nut or handwheel
6. Flange to ANSI B16.1 Class 125
7. Face to Face dimensions conforms to AWWA C504 Short Body
8. Shaft Diameter Class 250B
9. Working Pressure: 150 psi wwp (Class 150B) and 250 psi wwp (Class 250B)
10. Working Temperature: -10°C to 120°C for EPDM  
-10°C to 82°C for NBR
11. Inside and outside liquid epoxy painting or fusion bonded epoxy powder coated (FBE) to C550

**DIMENSIONS**

Size (in.)	Part No.	L	H	B	H1	H2	d	FA	Wk	W	Handwheel O.D.	Key Qty.	Torque (ft. lbs.)
30"	3975-F-400	12	24.5	22.5	5.1	4.9	3.5	10	1	40	24	2	4,850
36"	3975-F-460	12	28.6	26.6	6.1	5.5	4.3	11.7	1.1	47.6	24	2	7,900
42"	3975-F-520	12	32.3	30.4	6.9	6.3	4.7	14.0	1.3	54.6	24	2	11,700
48"	3975-F-580	15	35	33.5	9.1	8.3	5.3	14	1.4	60.3	24	2	17,000
54"	3975-F-640	15	39	37.7	9.1	8.3	6.4	16	1.6	67	24	2	25,500
60"	3975-F-700	15	42.8	41.6	9.1	8.3	7	16	1.8	73.8	24	2	32,900
64"	3975-F-740	18	49.1	47.9	13	12.6	7.5	19	1.8	80.8	24	2	42,500
72"	3975-F-820	18	52.2	50.9	13	12.60	8.3	19	2	87.3	24	2	55,000

Design and materials are subject to change without notice.



**WARNING:** This product can expose you to chemicals including lead, which is known to the State of California to cause cancer and birth defects or other reproductive harm. For more information go to [www.P65Warnings.ca.gov](http://www.P65Warnings.ca.gov).



**United Water Products**  
5355 Ramona Blvd., Jacksonville, FL 32205  
TEL. 877-766-4459 FAX: 877-766-4458  
Website: [www.unitedwaterproducts.com](http://www.unitedwaterproducts.com)